



**Air International
Transit**

SIGMA
Innovative by design • Tough by nature

AIR CONDITIONERS Heavy & Severe Duty Range

M15A

SPECIFICATION DATA

Model No:	M15A
Unit Type:	Roof Mounted Package
Cooling Capacity:	15 kW
Heating Capacity:	9 kW
Supply Airflow :	800 l/s
Pressurised Fresh Air :	100 l/s
Current Draw:	26 Amps
Voltage:	415VAC/3 Phase/50 Hz
Design Ambient:	46°C
Refrigerant:	R134a
Weight (Nominal):	655 kg's

For more information on the Sigma range of Air Conditioners, please contact one of our offices listed below. In the interests of product improvement, Air International Transit, reserves the right to alter specifications without notice.

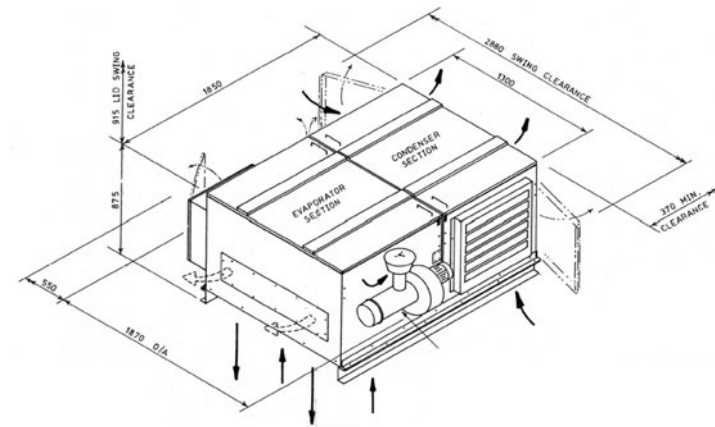

**Air International
Transit**

AIR INTERNATIONAL TRANSIT
A LLOYD'S QUALITY ACCREDITED COMPANY



HEAD OFFICE: 3 Distillers Place, Huntingwood NSW 2148
Phone: + 61 2 9830 7100 Fax: + 61 2 9672 1018

QUEENSLAND: 16 Machinery Street, Darra QLD 4076
Phone: + 61 7 3713 7411 Fax: + 61 7 3713 7422

VICTORIA: 245 Collins St, Thornbury VIC 3071
Phone: + 61 3 9416 8511 Fax: + 61 3 9416 8911

WEB: www.airinter.com.au

EMAIL: ait@airinter.com.au