



**Sigma Coachair
Group**

M15A



AIR CONDITIONERS
Heavy & Severe Duty Range

SPECIFICATION DATA

Model No:	M15A
Unit Type:	Roof Mounted Package
Cooling Capacity:	15 kW
Heating Capacity:	9 kW
Supply Airflow :	800 l/s
Pressurised Fresh Air :	100 l/s
Current Draw:	26 Amps
Voltage:	415VAC/3 Phase/50 Hz
Design Ambient:	46°C
Refrigerant:	R134a
Weight (Nominal):	655 kg's

For more information on the Sigma range of Air Conditioners, please contact one of our offices listed below. In the interests of product improvement, Sigma Coachair Group, reserves the right to alter specifications without notice.

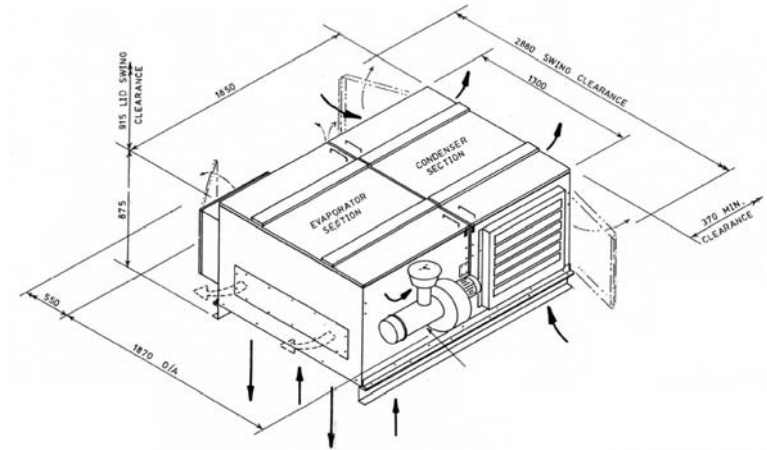

**Sigma Coachair
Group**

SIGMA COACHAIR GROUP

A LLOYD'S QUALITY ACCREDITED COMPANY



HEAD OFFICE: 11 McILWRAITH Street, Wetherill Park NSW 2164
Phone: + 61 2 9827 0000 Fax: + 61 2 9756 2866

NEW SOUTH WALES: 27 Tarlington Place, Smithfield, NSW 2148
Phone: + 61 2 9765 2800 Fax: + 61 2 9765 2899

QUEENSLAND: 16 Machinery Street, Darra QLD 4076
Phone: + 61 7 3713 7411 Fax: + 61 7 3713 7422

VICTORIA: 28 Trade Park Drive, Tullamarine VIC 3043
Phone: + 61 3 8336 8700 Fax: + 61 3 9330 4488

WEB: www.sigmacoachair.com

EMAIL: scg@sigmacoachair.com